

DATE	LOCATION
Wednesday, April 15th, 2020	NSCC Marconi Campus

1. Schedule

Time	Task
8:30 am – 9:00 am	Orientation
9:00 am – 10:00 am	Project begins
10:00 am – 10:20 am	Break
10:20 am – 12:00 pm	Continue project
12:00 pm – 12:45 pm	Lunch (provided)
12:45 pm – 2:00 pm	Continue project
2:00 pm	Project ends
2:00 pm – 3:00 pm	Judging

2. Purpose of the Contest

To assess each contestant's competence in the welding trade. Competitors must demonstrate their ability to read plans, interpret welding symbols and display their expertise using the SMAW & GMAW welding processes.

3. Criteria

4. Number of Stations / Allocations

There is a maximum of twelve (12) spaces available with local exhaust.

5. Skills & Knowledge to be Tested

Students will be expected to:

- Check that the dimensions of the materials are in accordance with the material list and the print / drawings;
- Assemble the materials in accordance with the prints / drawings provided;
- Utilize their practical skills in prints / drawings interpretation, layout;
- Demonstrate an ability to read blueprints and interpret welding symbols and abbreviations;
- Have a working knowledge of electrode classification and identification.

Safety Requirements:

- Safety awareness / requirements will be maintained within minimum industry standards at all times;
- A contestant will not be allowed to compete without the safety equipment listed in this document.

6. Prerequisites

SCNS Prerequisites

- Attend a public or private secondary institute;
- Be between 13 and 21 years of age on January 1 of the year of the Competition;
- Have been earning junior or senior high school credits any time during the current academic year (September to June);
- Be registered as a competitor with Skills Canada – Nova Scotia;
- Possess a Canadian citizenship or landed immigrant status and be a resident of Nova Scotia. Competitors are responsible for verifying this information if requested;
- Have completed and submitted a signed release form by a parent or guardian, if under the age of 19.

7. Equipment & Clothing

a) What Will Be Supplied

- All welding equipment, materials and consumables;
- All instructions and procedure sheets with drawings;
- Welding jacket;
- Leather apron;
- Ear plugs;
- Material for machine setup and practice beads.

b) What Competitors Must Supply

- Welding Helmet w/ #10, #11 and / or #12 lens;
- Safety glasses;
- Hat or beanie;
- CSA approved steel-toed boots;
- Coveralls;
- Leather gauntlet welding gloves;
- Fitters gloves.

Tools

- Tool box;
- Chipping hammer;
- Steel wire brush;
- Measuring tape;
- Soapstone / metal marker;
- Fillet weld gauge;
- 12" tri-square;
- All-purpose pliers (for G.M.A.W);
- Vice grips (for holding hot metal).

8. Evaluation & Judging Criteria

Task	Point Value / Percentage
Layout <ul style="list-style-type: none"> • Sequence of steps followed as per instructions; • Proper tools used for layout; • Measurements meet prints / drawings specs. 	15%
Accuracy of Assembly <ul style="list-style-type: none"> • Finished dimensions accurate; • Pieces aligned squarely, as required. 	10%
Quality of Shielded Metal Arc Welding <ul style="list-style-type: none"> • Are weld sizes as per drawing? • Are welds correctly located? • Consistent contour and weld profile; • Absence of defects (porosity, undercut, arc strikes); • Is all spatter removed? • Is good fusion evident? • Is welding consistent? • Conforms to drawings. 	25%
Quality of Gas Metal Arc Welding <ul style="list-style-type: none"> • Are weld sizes as per drawing? • Are welds correctly located? 	25%

<ul style="list-style-type: none"> • Consistent contour and weld profile; • Absence of defects (porosity, undercut, arc strikes); • Is all spatter removed? • Is good fusion evident? • Is welding consistent? • Conforms to drawings. 	
<p>General Workmanship</p> <ul style="list-style-type: none"> • Has proper cleaning been done? • Is distortion evident? • Has pre-setting been done? 	15%
<p>Safety - evaluated before, during and after work;</p> <p>Does the competitor:</p> <ul style="list-style-type: none"> • Wear suitable clothing? • Have personal safety equipment? • Wear eye protection at all times? • Wear ear protection when required? • Employ safe layout practices? • Employ safe arc welding practices? 	10%
TOTAL	100%

No ties are permitted. In the event of a tie, the winner shall be the competitor that finishes the project first.

9. Additional Information

- Late arrivals will be allowed to enter the competition within ½ an hour;
- No butane lighters or matches allowed in the welding area;
- No talking to other students that may be in or watching the competition;
- No magnets allowed to hold metal in place;
- Lunch and break food will be delivered to the shop.
- During break times competitors must leave their project in their welding booth and not re-enter until competition resumes;
- The judges for the welding competition will include persons that work in the welding trade;
- Other shop rules will be reviewed prior to competition.

10. PTC Contact Information

Name	Employer	Email
Quentin MacDonald	NSCC Marconi Campus	quentin.macdonald@nsc.ca
Terry Keating	NSCC Marconi Campus	terrance.keating@nsc.ca

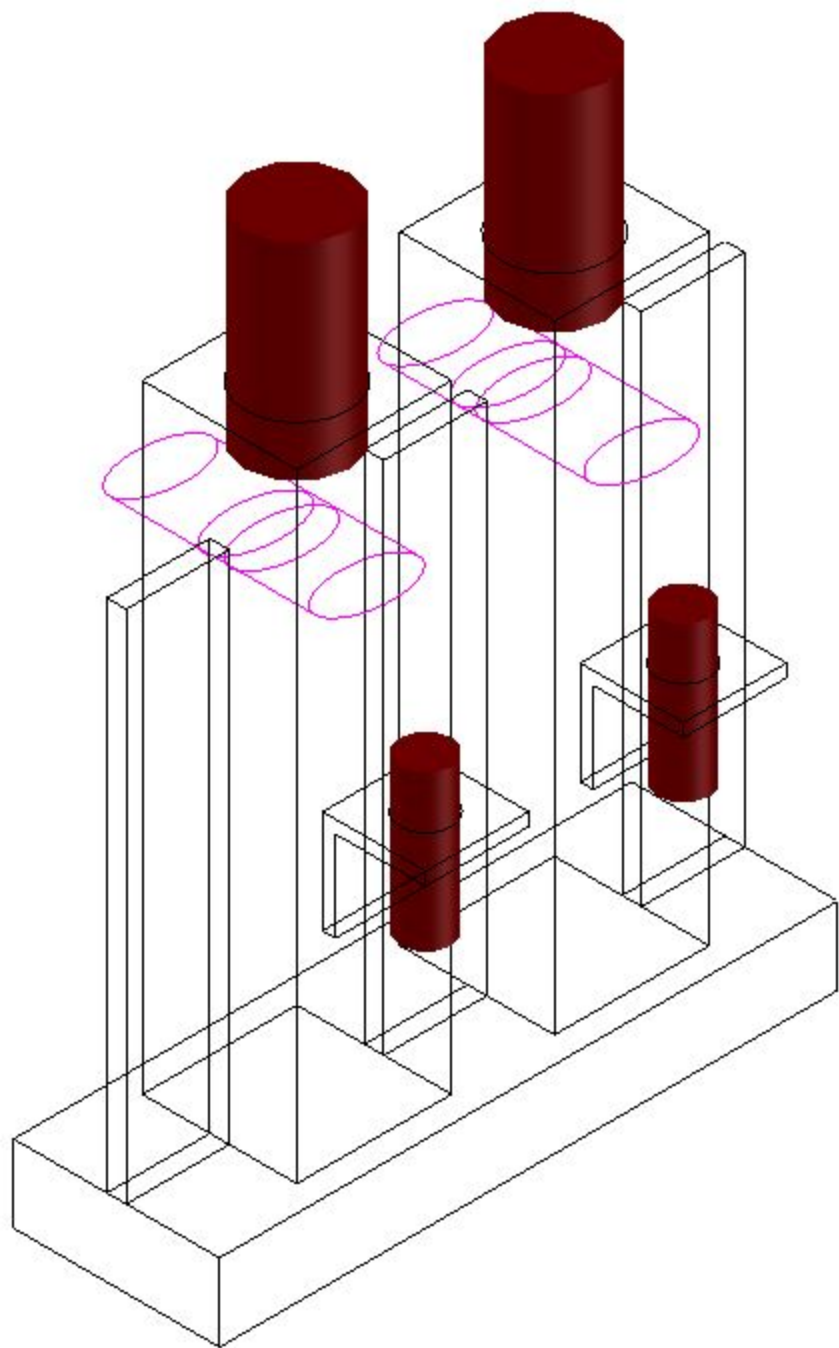

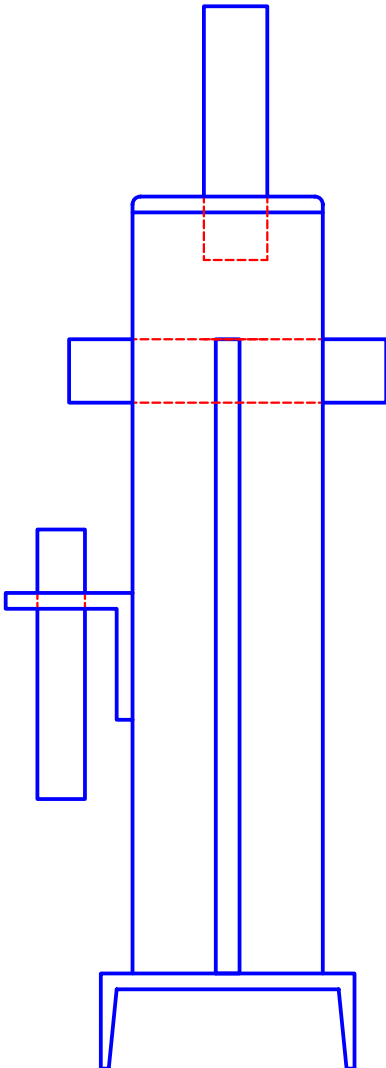
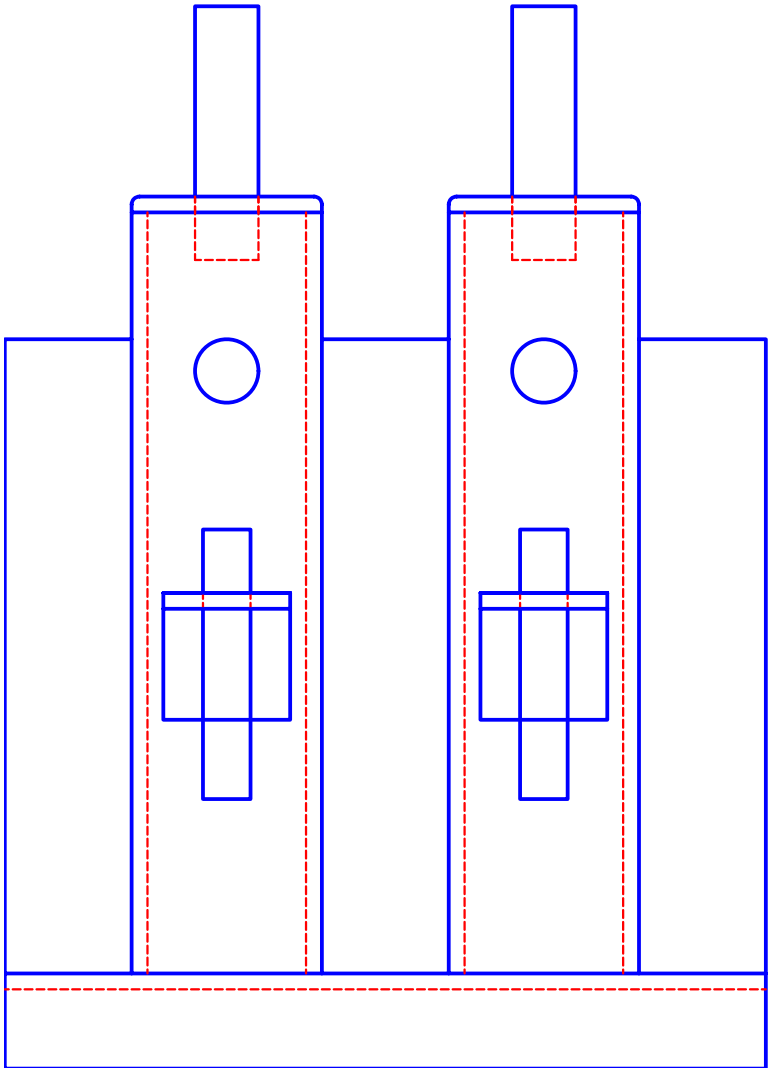
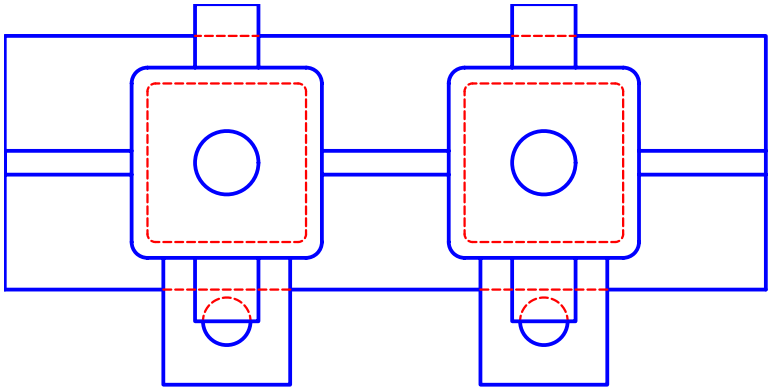

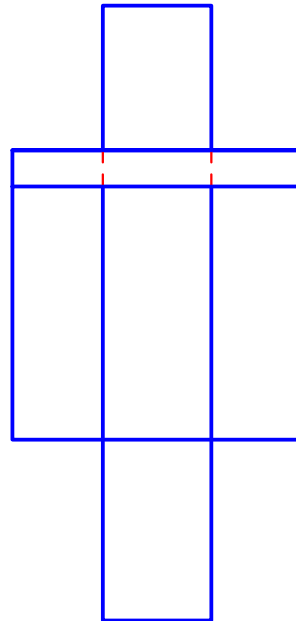
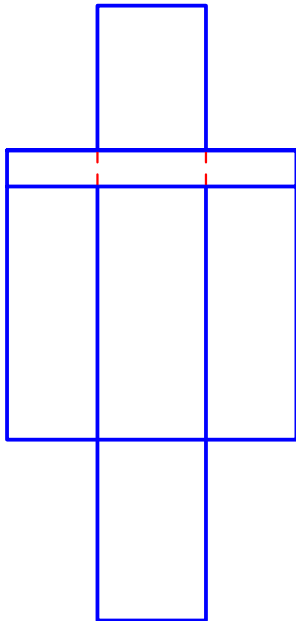

Marconi

Campus

wordmark_02_black.tif

PART NAME

DR. BY: L. Boyd
CHK. BY:

SC: FULL
11 OCT 2009

Welding I

REV.
XX

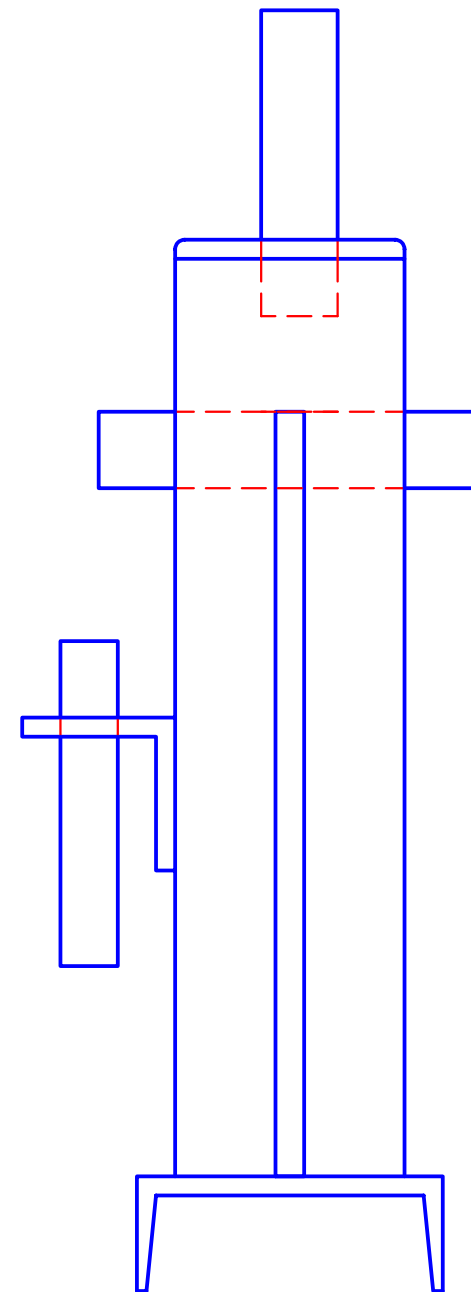
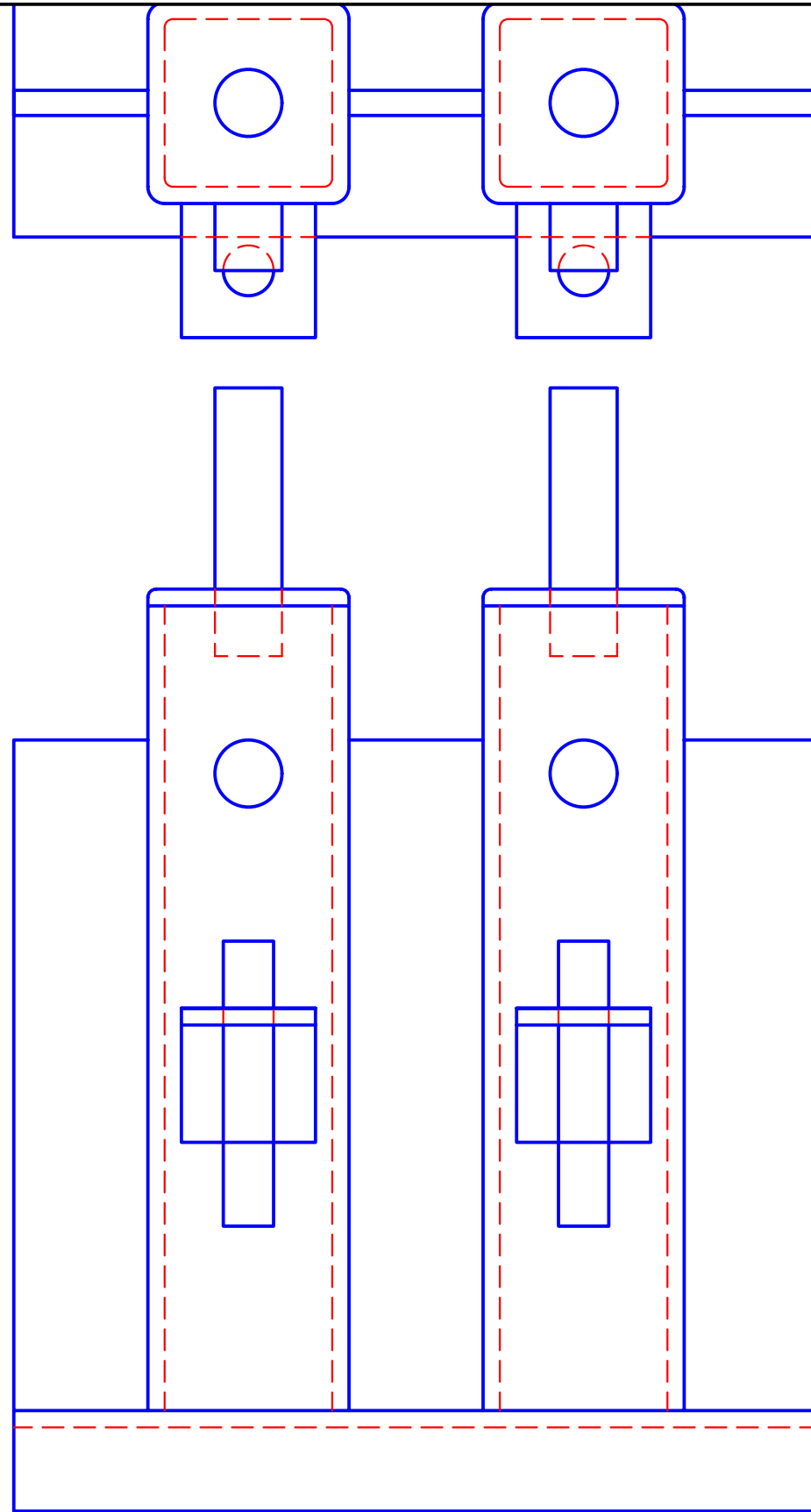

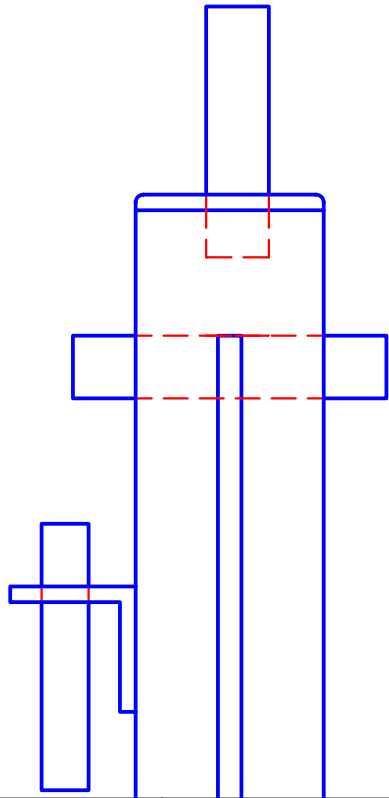
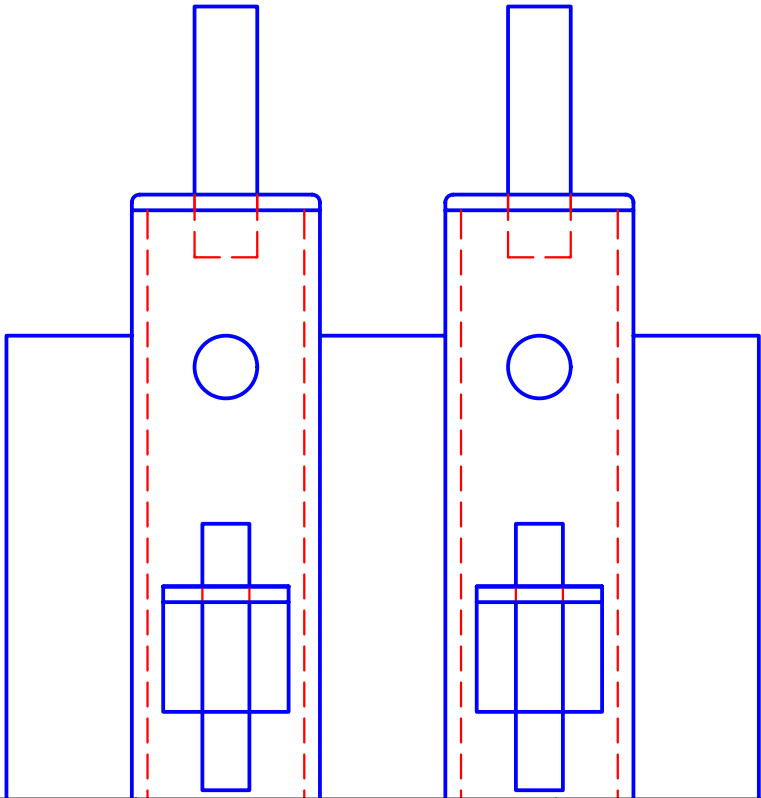
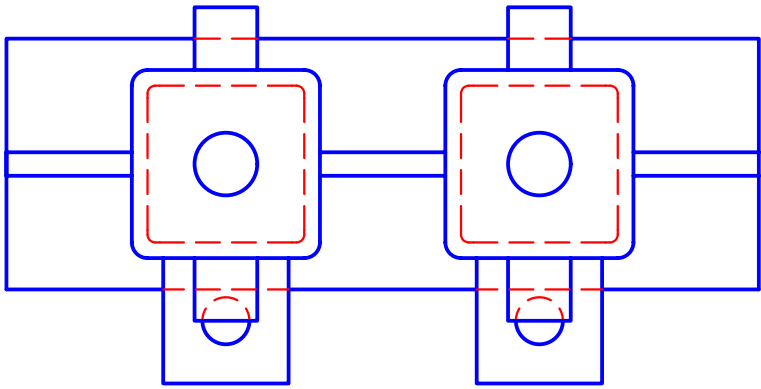

**Marconi
CAMPUS**

PART NAME

DR. BY: L. BOYD
CHK. BY:

SCALE: FULL SIZE
DATE: 11 SEPT 2009

Welding I

REV.
XX

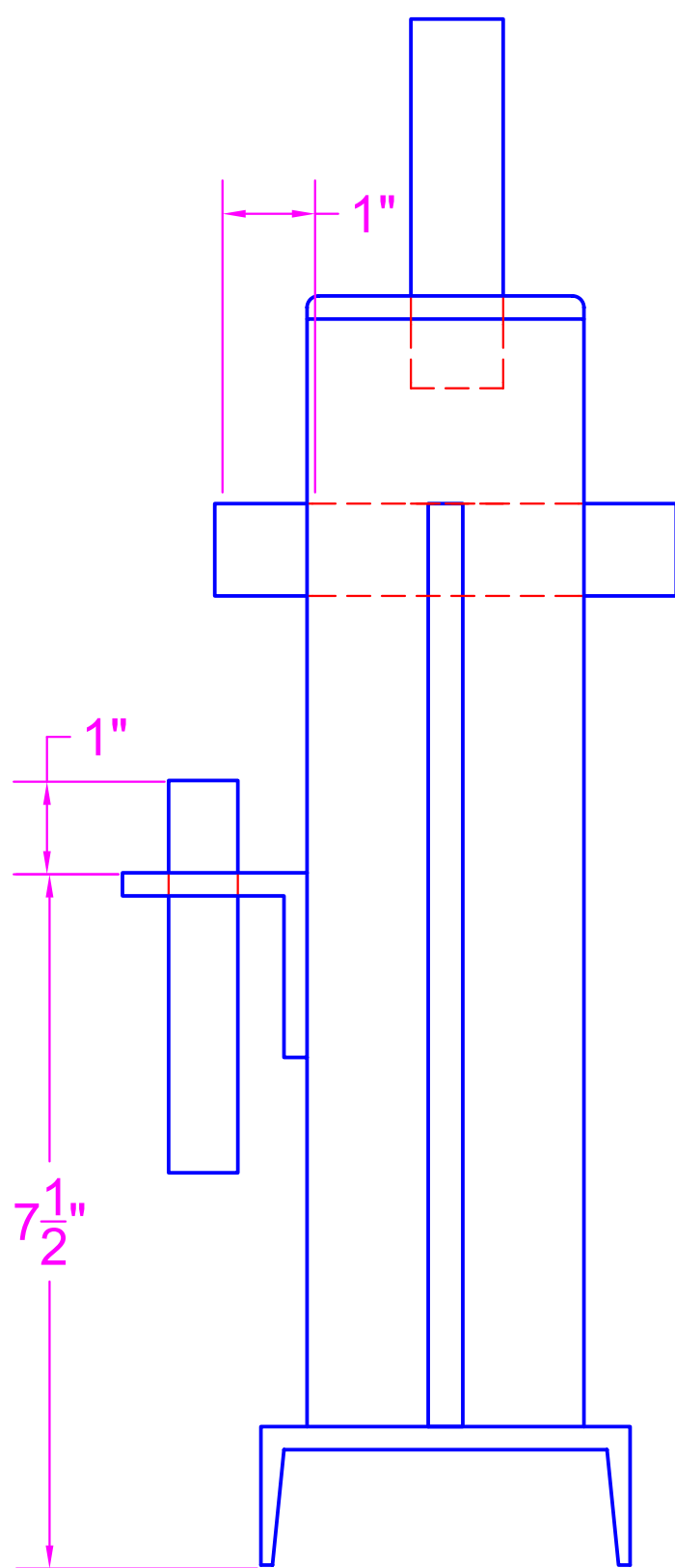
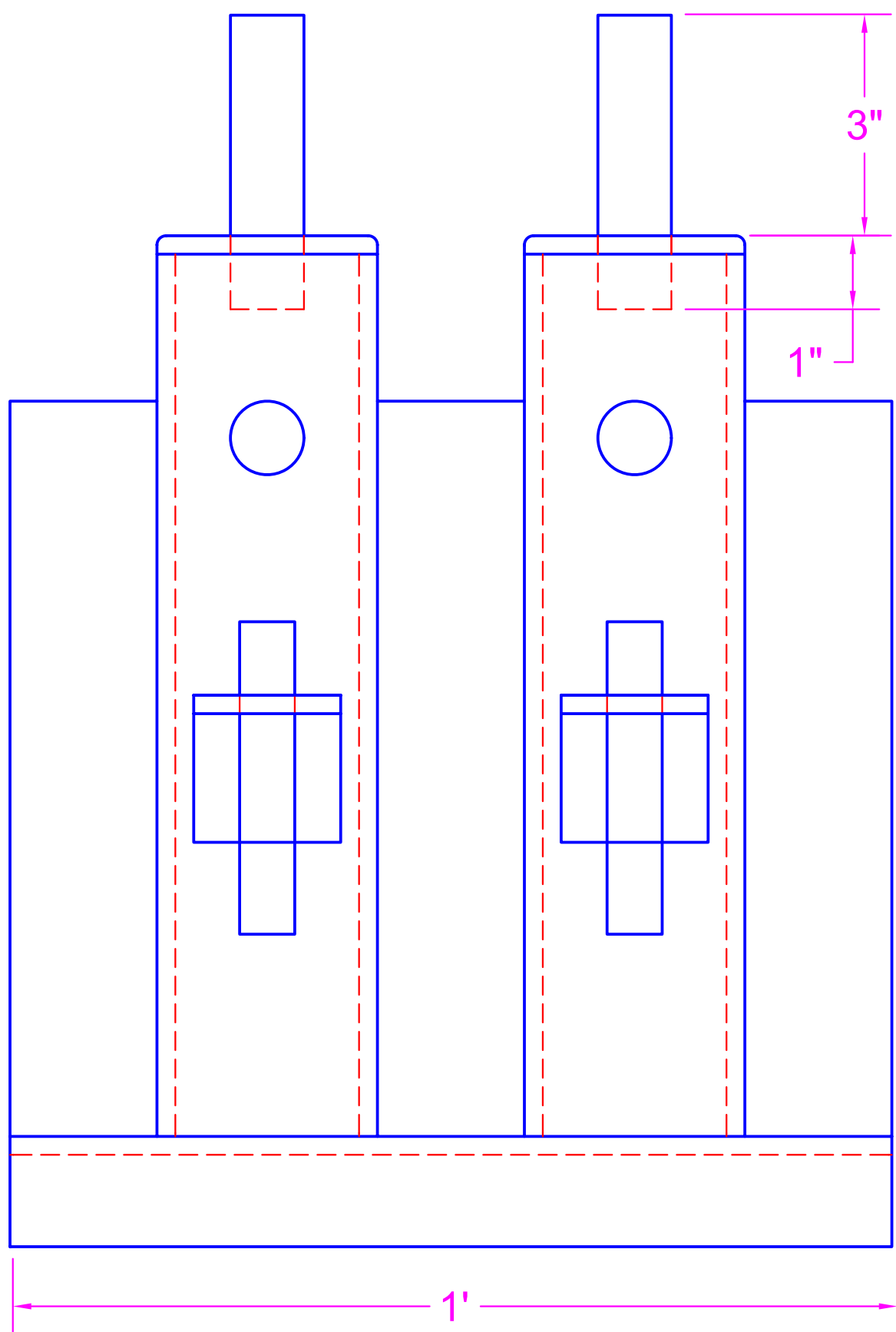
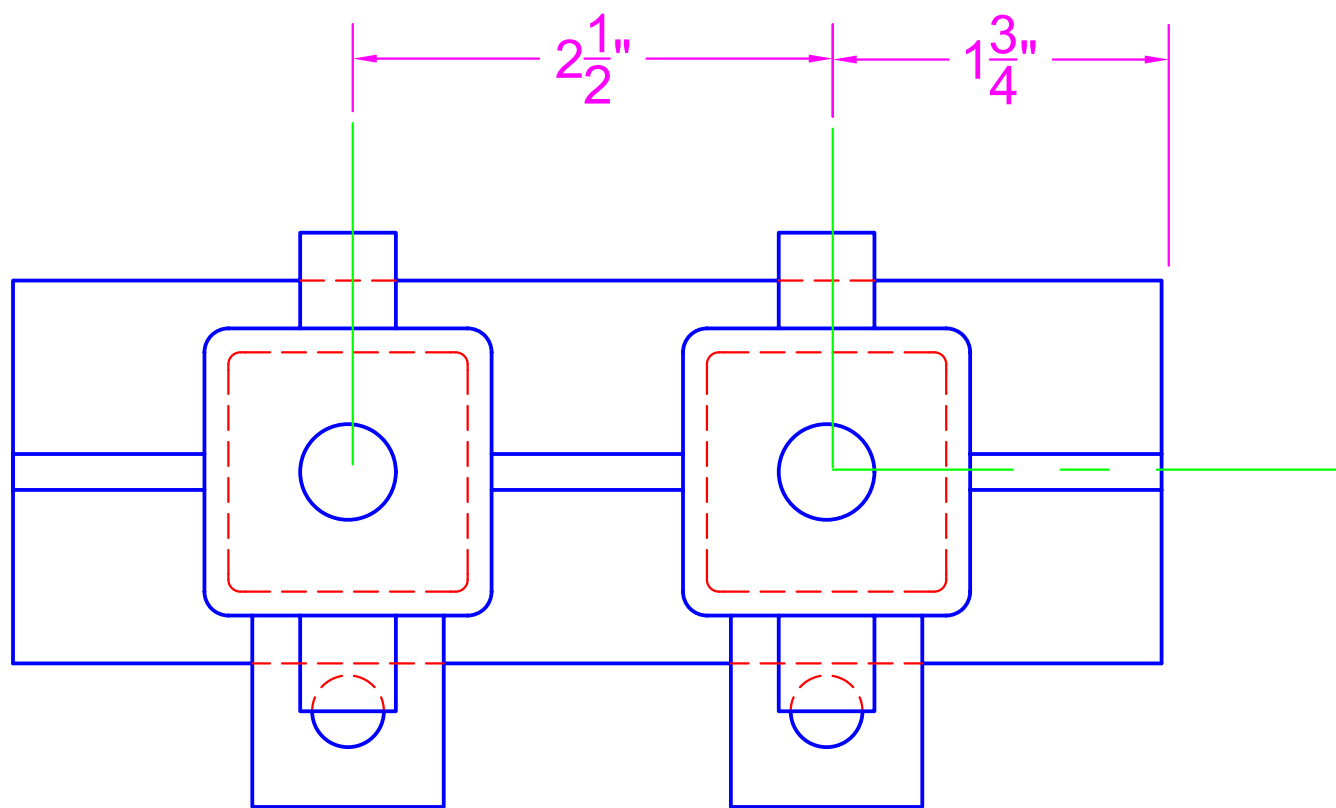

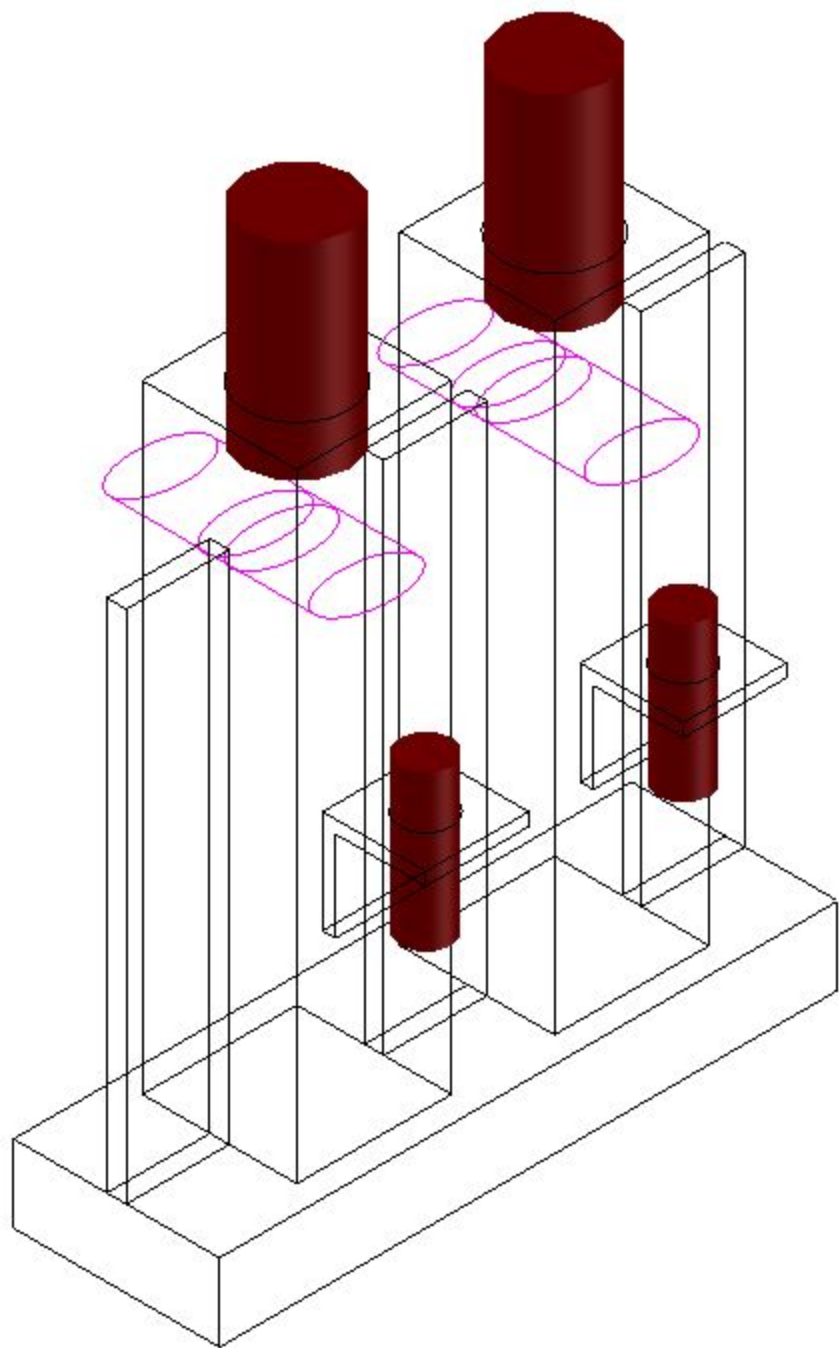

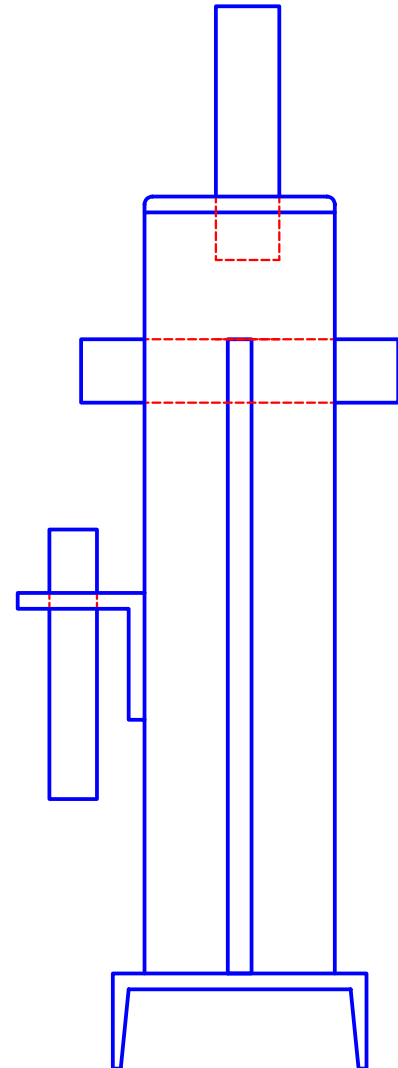
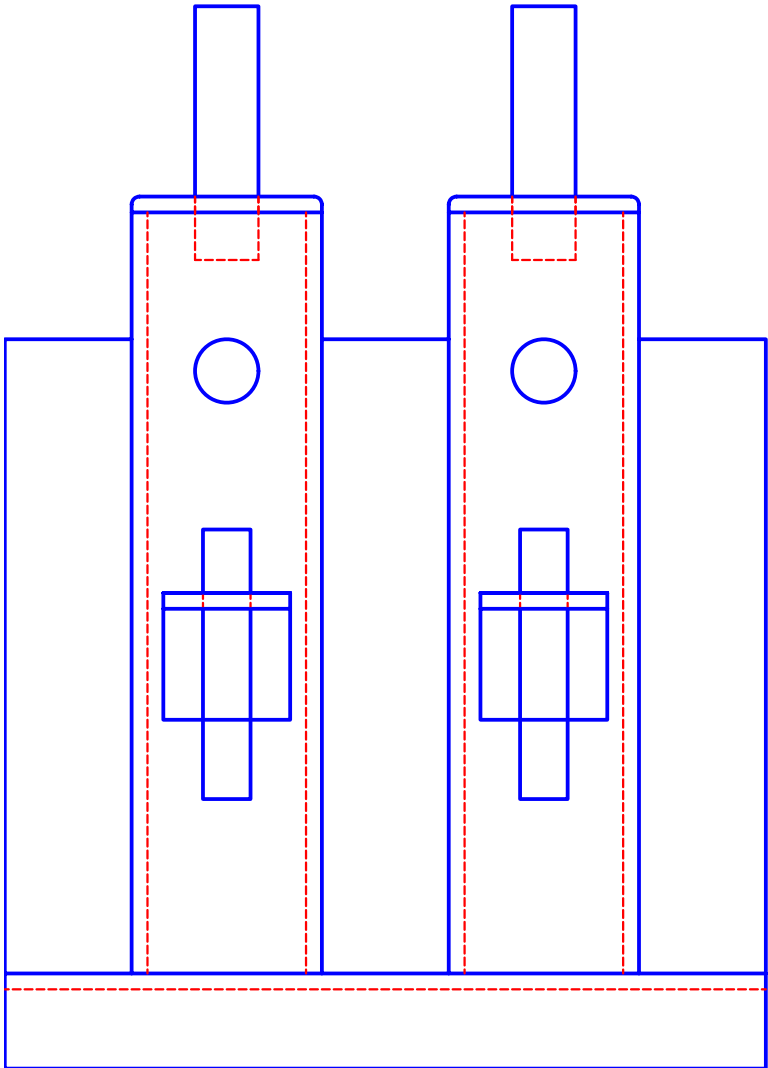
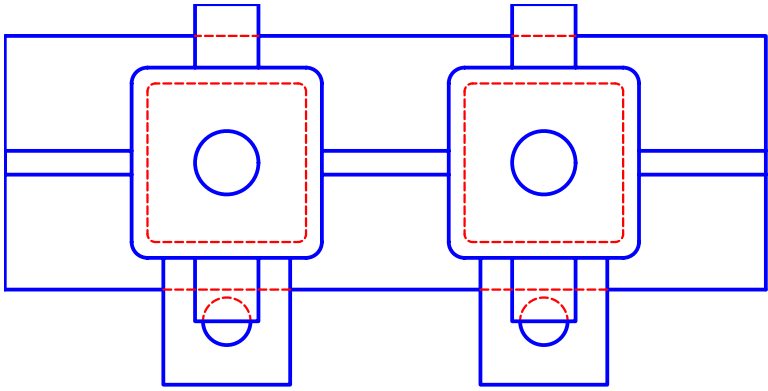

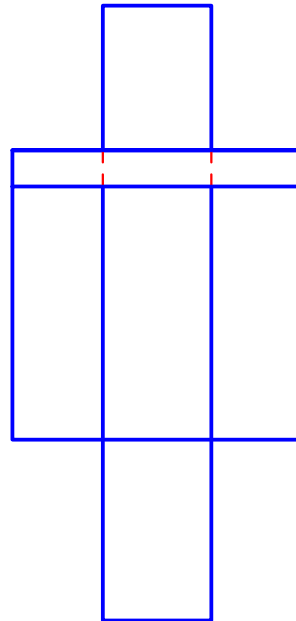
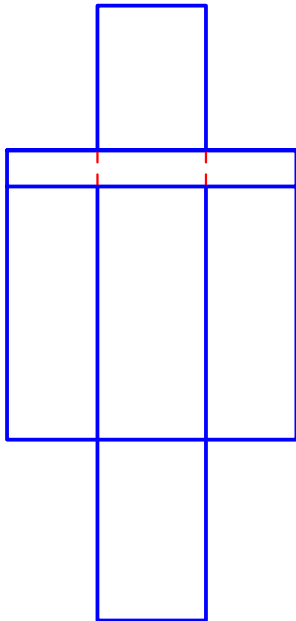

wordmark_02_black.tif STRAIT AREA
CAMPUS

PART NAME

DR. BY: L. Boyd
CHK. BY:

SC: FULL
11 OCT 2009

Welding I

REV.
XX

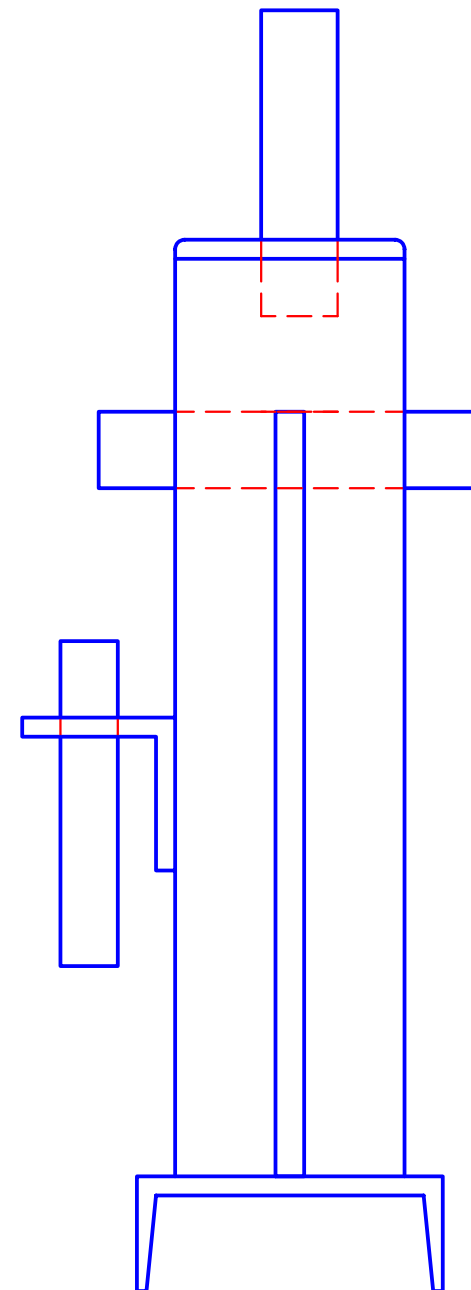
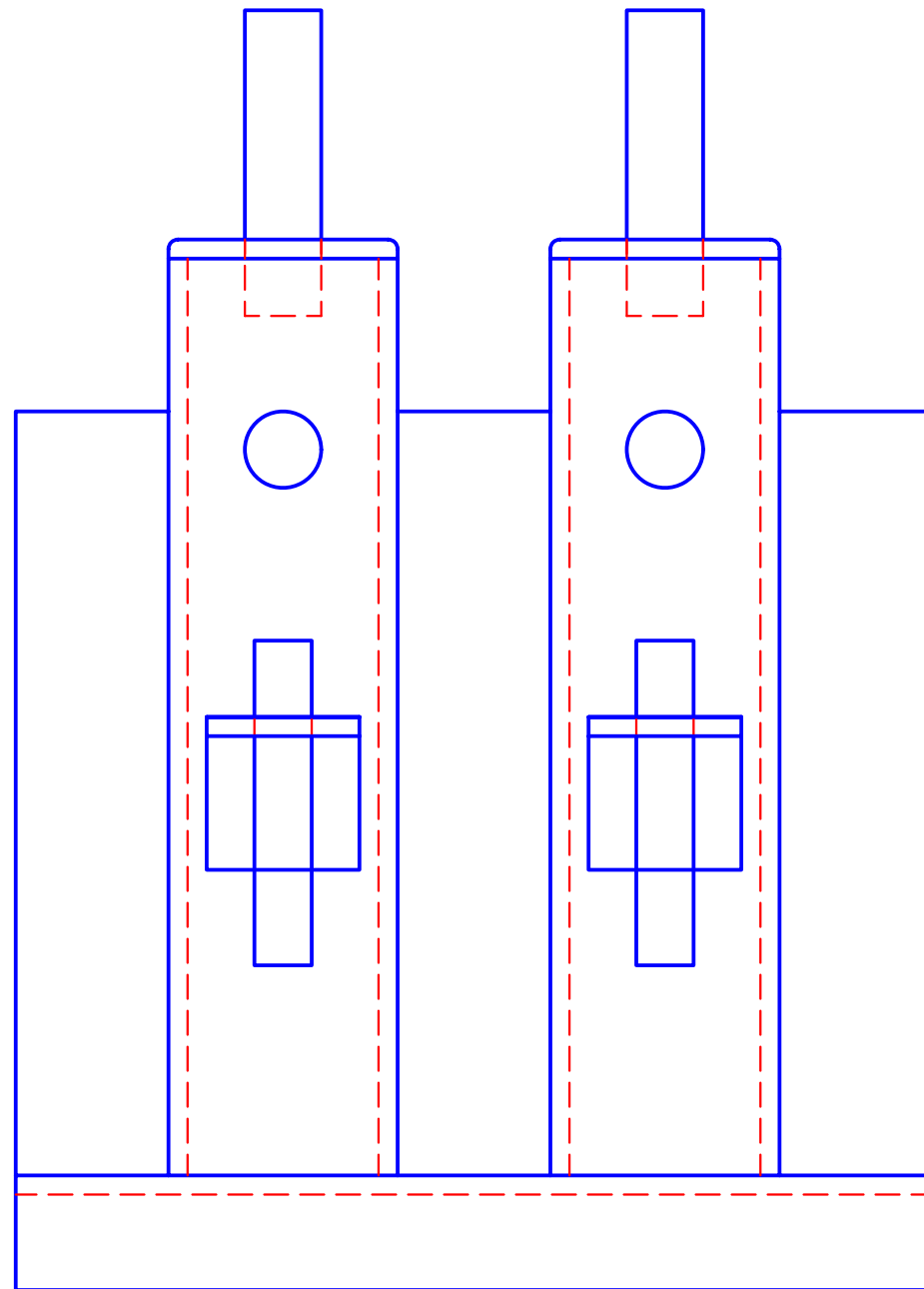
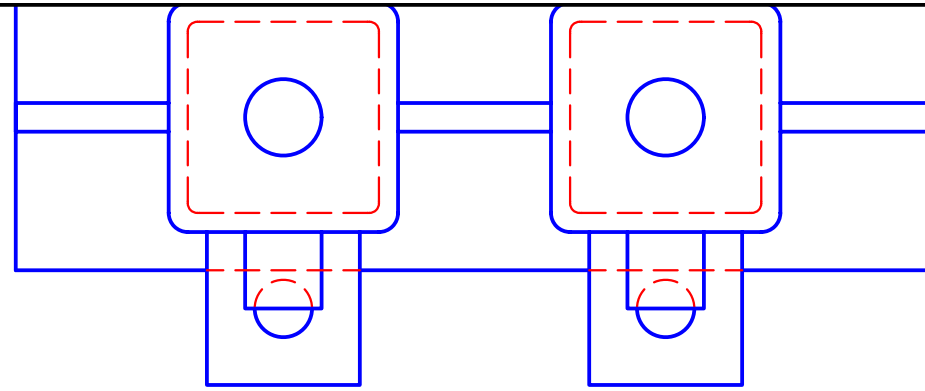

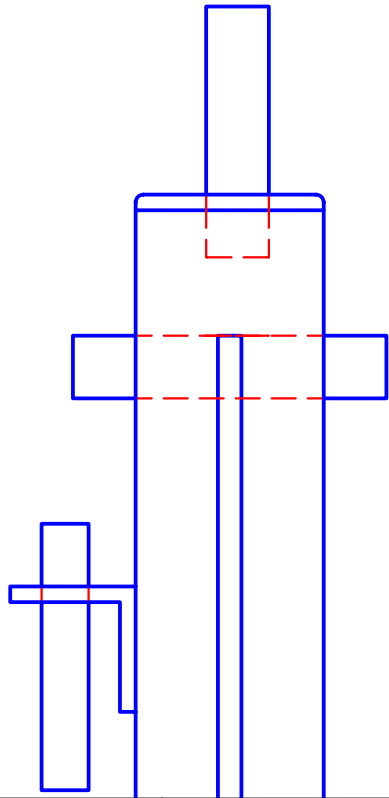
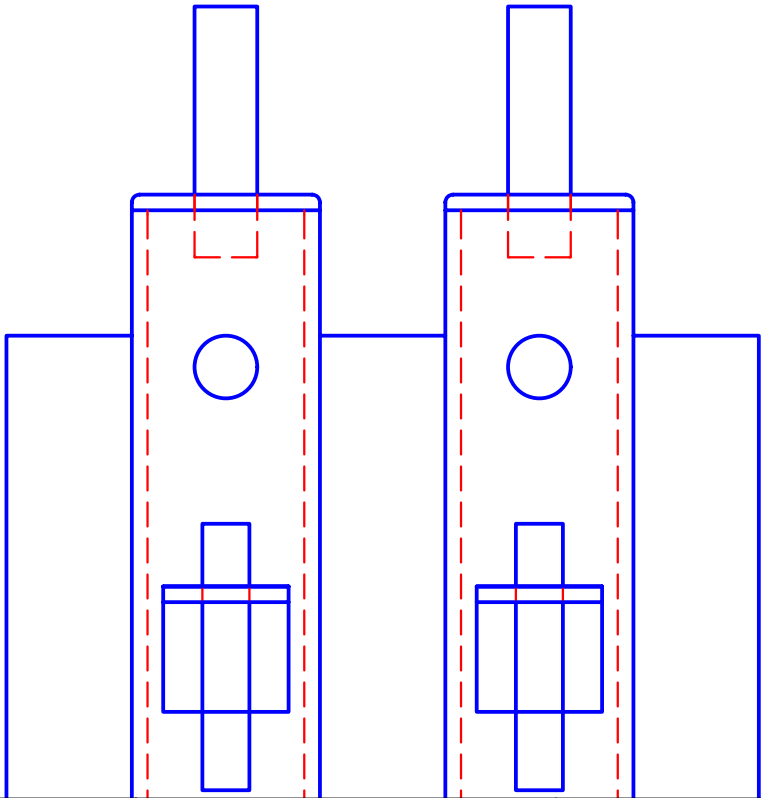
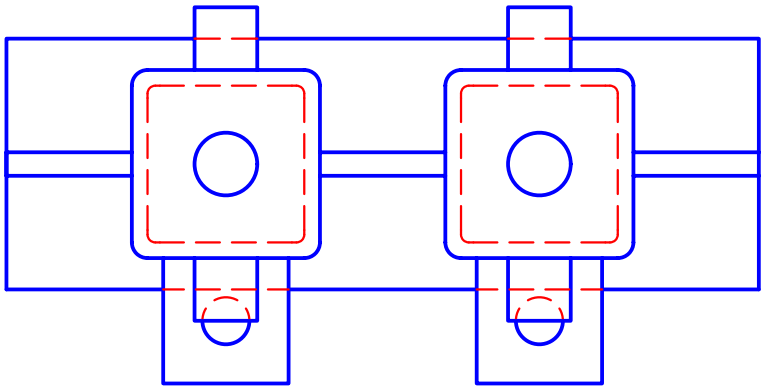

**STRAIT AREA
CAMPUS**

PART NAME

DR. BY: L. BOYD
CHK. BY:

SCALE: FULL SIZE
DATE: 11 SEPT 2009

Welding I

REV.
XX

